

PERFORMANCE DATA

FEEDER (TIER 3)

BMF 2500

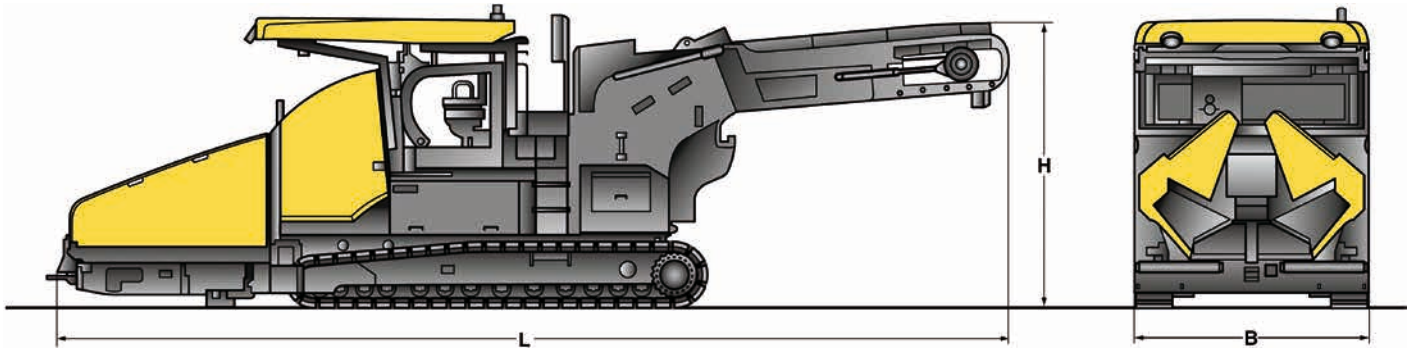



Dimensions in m

	Length	Width	Height
BMF 2500 S	9,20	2,55	3,10
BMF 2500 M	10,26	2,55	3,10
BMF 2500 S Offset	13,50	2,55	3,10

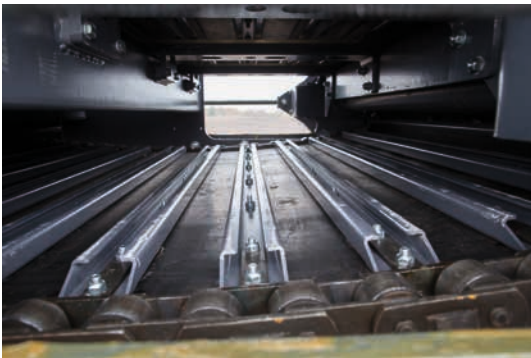

Work reliably – the chain-reinforced conveyor belt prevents downtime.



Flexible in use – the optionally available swivel wheel for the BMF 2500 S.



Counteract demixing – a width of 1.20 m ensures gentle material transport.



Everything in sight – the optional lift platform provides the best overview.

Technical Data

BOMAG BMF 2500 S

Weights

Operating weight CECE	kg	20000
BMF 2500 M	kg	20500
BMF 2500 S Offset	kg	24500

Dimensions

Transport length BMF 2500 S	mm	9200
BMF 2500 M	mm	10260
BMF 2500 S Offset	mm	13500
Transport width BMF 2500 S	mm	9200
BMF 2500 M	mm	3000
BMF 2500 S Offset	mm	13500
Transport height	mm	3100
Loading angle	°	10

Travel characteristics

Travel speed	km/h	0-4
Working speed	m/min	0-25 variable

Drive

Engine manufacturer		Cummins
Type		QSB6.7-C260
Exhaust classification		Stage III a / TIER 3
Cooling		Fluid
Number of cylinders		6
Displacement	cm ³	6700
Rated power	kW / hp	170 / 231
Power	rpm	2200

Track chains

Overall length	mm	3900
Width	mm	320

Hopper

Capacity	m ³ / t	7 / 15
Width (wings open)	mm	3345
Width (wings closed)	mm	2550
Length	mm	2200
Filling height (middle)	mm	523

Conveyor belt

Type		Rubber band, mounted on two roller chains, with metal cross ties
Velocity		Infinitely variable
Width	mm	1200
Conveying height BM 2500 S / BMF 2500 M	mm	2180 mm (with hydraulic height adjustment 2560 mm)
Conveying height BM 2500 S Offset		2900
Capacity	t/h	4000

Filling capacities

Fuel	l	300
Hydraulic system	l	200

Electric system

Voltage	V	24
---------------	---	----

Technical modifications reserved. Machines may be shown with options.

Standard equipment

Operator's platform

- 2 driver's seats slewable and rotatable
- Protection, dashboard
- Adjustable dashboard
- Hydraulically foldable roof
- Digital display for machine management
- Weather protection roof

Tractive unit

- Fuel tank 300 litres
- Individual control of bucket flaps
- Track chain scraper
- Rubber floor plates
- Hydraulic hopper front flap
- Cleaning kit
- Pre-installation of swivelling conveyor

Conveyor belt

- Central lubrication of conveyor belt chain
- Scraper for conveyor belt
- Automatic conveyor belt cleaning system

Assistance systems

- On-board tool
- Automatic distance control
- Automatic loading assistant
- Laptop Station

Miscellaneous

- 7 Halogen working lights
- Flashing beacon
- Backup alarm
- 2 x 24 V sockets
- 1 x 12 V socket
- Storage compartments

Optional equipment

Operator's platform

- Weather protection for platform
- Comfort seat with seat heating
- Height adjustable lift platform

Tractive unit

- Special paint finish
- Bio-degradable hydraulic oil
- Camera system
- Signal lamp system

Conveyor belt

- Slewable belt
(only for model BMF 2500 S)
- Slewable belt covering
- LED lighting for slewable conveyor
- Camera system for slewable belt
- Hydraulic height adjustment for conveyor belt

Assistance systems

- Automatic steering (max. 14.0 M)
- Automatic steering (max. 10.0 M)

Miscellaneous

- Fleet management BOMAG TELEMATIC
- Illumination balloon (24 V, 250 W)
- LED Roof illumination
- LED illumination of short and medium conveyor belts
- Fire extinguisher
- Coming Home light function
- Illumination of engine compartment

