

# RAMMER RGP09R GRAPPLE



## SAFETY VALVE

Avoids material falling off the shells in case of hyd oil missing. Very important SAFETY feature to avoid dangerous accidents.

## MANUFACTURED FROM HB400 STEEL

High wear resistance of the components. Equipment can work on most demanding conditions.

## STROKE HYDRAULIC BRAKE

Components longer life due to less stress. Less maintenance > lower owning and operating costs.

## BOLT ON REPLACEABLE CUTTING BLADES

Can be turned to extend their life before replacing. Less maintenance > lower owning and operating costs.

## LIGHT AND STRONG ENOUGH

Can be used on soft and demanding applications such as demolition and recycling. Faster pay off.

## EXTERNAL ACCESS FOR SERVICING

Faster service intervals  
Less downtime > better productivity.

## HARDENED BUSHINGS AND PINS

Higher wear resistance therefore longer life.  
Lower owning and operating costs.

## MECHANICAL CILYNDER STOPPERS

Avoids premature stress at cilynders  
Lower owning and operating costs.

## RPV GRAPPLE

Rammer RGP Grapples have been designed and tested with demolition in mind. The RGP Grapples are suitable for demolition and material handling applications: robust for heavy work, but also accurate for picking and sorting applications. They offer large volume for bulk loading, making it also ideal for waste handling.

**Rammer**<sup>®</sup>

# RGP09R

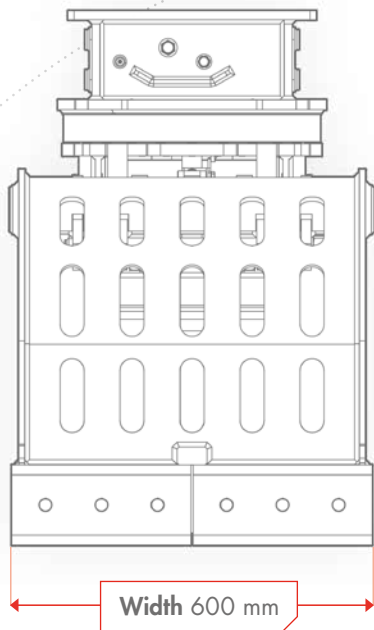

## SPECIFICATIONS

Working weight, kg	700
Capacity, liter	300
Working pressure, bar	250 - 300
Oil flow, l/min	20-30
Rotation oil pressure, bar	130-150
Rotation oil flow, l/min	15-20
Excavator weight, ton	7-11

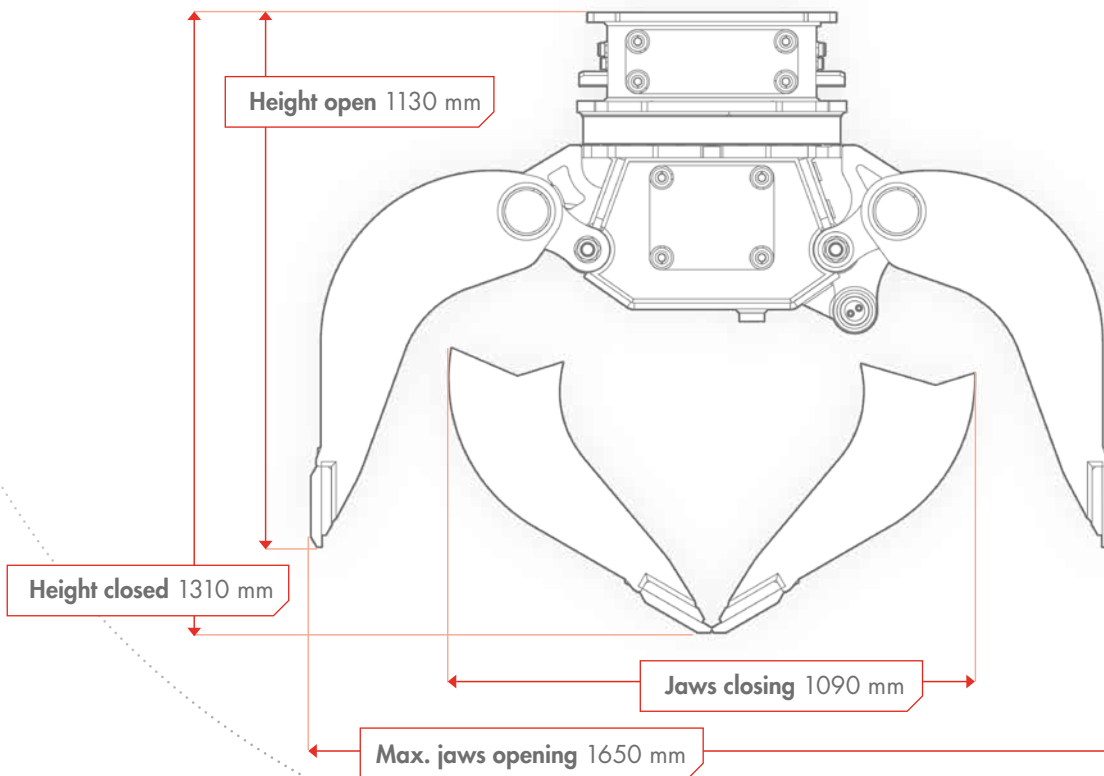

Sandvik Mining and Construction Oy  
Taivalkatu 8, P.O.Box 165  
FI-15101 Lahti, Finland  
Phone Int. +358 205 44 151  
[www.rammer.com](http://www.rammer.com)

**Ram  
mer**<sup>®</sup>