

RAMMER RPV07S STATIC PULVERIZER



SPEED VALVE

Shorter working cycles
increase productivity

FIELD REPLACEABLE WEAR PARTS

Minimise downtime as there is no need for welding/rebuilding

HEAT TREATED PINS AND BUSHINGS

Hardened parts are more wear resistant, extending their working life and lowering owning and operating costs

GRATED JAW DESIGN

The fixed jaw allows crushed material to pass through increasing productivity

MANUFACTURED OF HB400 STEEL

Highly resistant material to work on concrete

BOLT ON CUTTING BLADES

Field replaceable and adjustable cutter blades minimize downtime and significantly increase the working life of wear parts

RPV STATIC PULVERIZERS

The Rammer RPV Static Pulverizer range is ideally suited to a wide range of secondary demolition and recycling duties. The RPV range of models are designed for fast and effective material separation, a key aspect of the recycling process.

**Ram
mer**[®]

RPV07S

SPECIFICATIONS

Working weight, kg	490
Operating pressure, bar	220-280
Oil flow, l/min	80-100
Blade length, mm	120
Carrier weight, range, ton	4-10

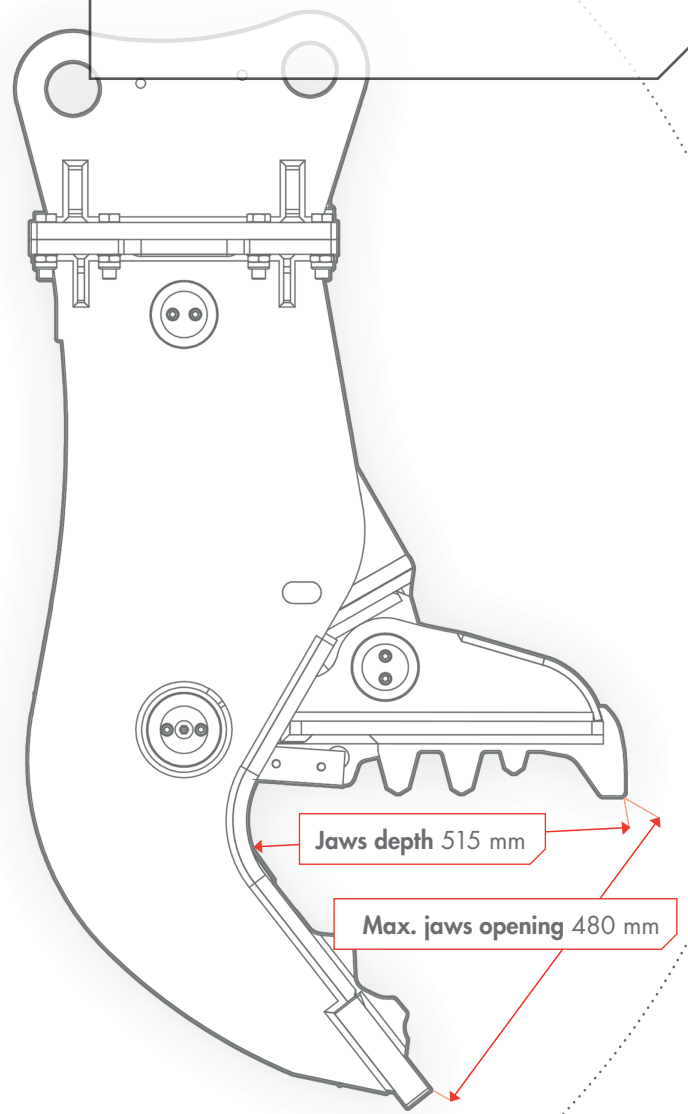
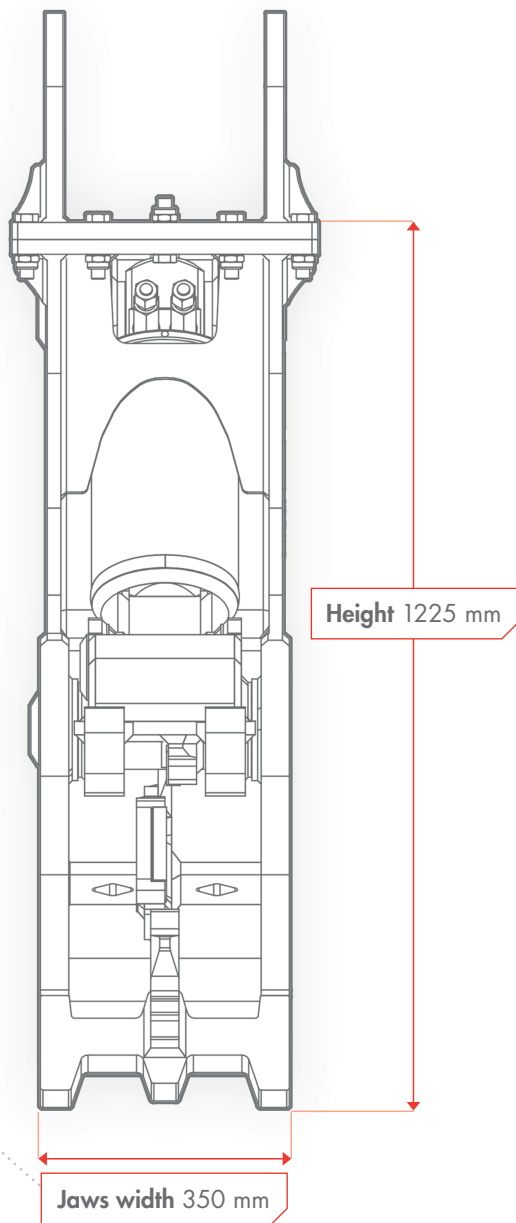

Sandvik Mining and Construction Oy
Taivalkatu 8, P.O.Box 165
FI-15101 Lahti, Finland
Phone Int. +358 205 44 151
www.rammer.com

