

RAMMER RSS11R SCRAP SHEAR

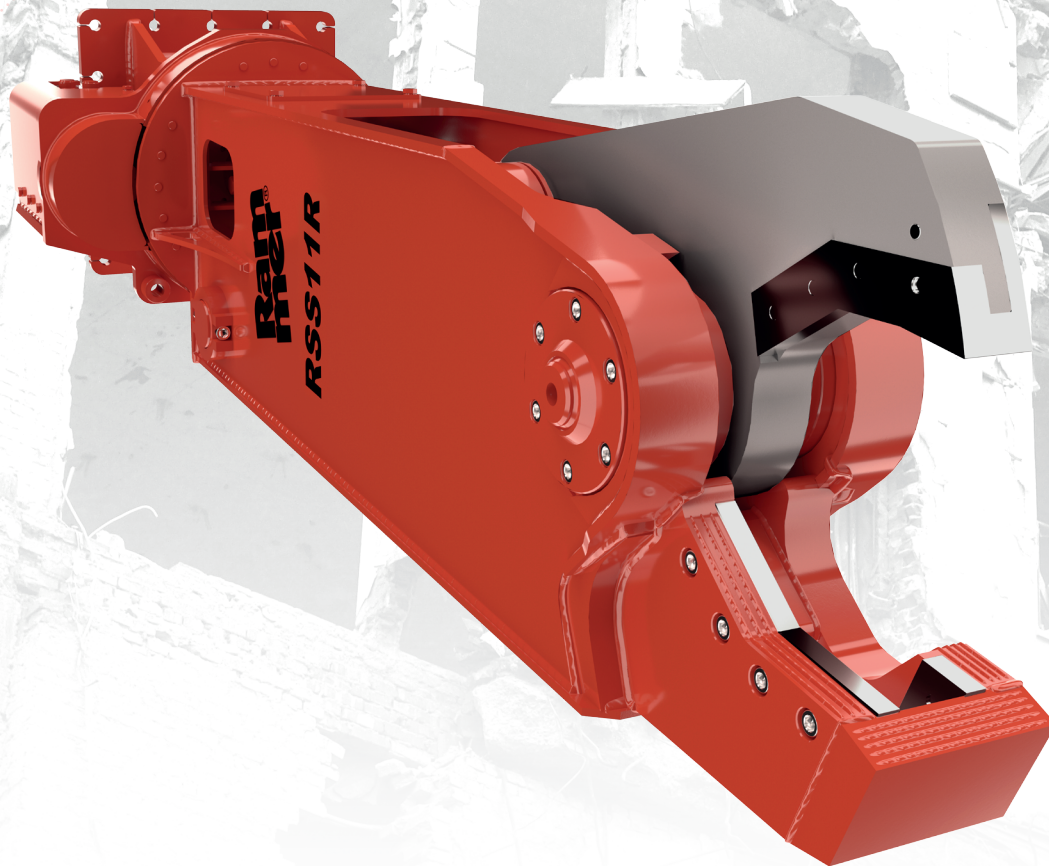

HYDRAULIC ROTATION WITH PROTECTION VALVE

The protected rotation system allows precision tool placement, lowering/reducing owning and operating costs.

BOLT ON, SYMMETRICAL CUTTER BLADES

Field replaceable and adjustable cutter blades minimize downtime and significantly increase the working life of wear parts

SMART JAWS DESIGN FEATURING DOUBLE GUIDE

Avoids material to stuck between the jaws which increases productivity and cutting capacity

SPEED VALVE

Shorter working cycles to increase productivity

HYDRAULIC CYLINDER SHIELDING

The cylinders are fully protected throughout the working cycle. Increasing durability and extending service intervals.

REPLACEABLE PEARCING TIP

A bolt on pearcing tip, removes the need for welding and rebuilding which lowers the cost of owning and operation.

FIELD REPLACEABLE AND ADJUSTABLE CENTRAL PIN

Enables the operator to maintain the product on the site keeping cutting capacity on the maximum level.

RSS SCRAP SHEARS

The RSS Scrap Shears can be used in every industrial demolition job involving the cutting and recovery of ferrous materials such as iron sections, pipes, tanks, railway carriages etc

**Ram
mer**[®]

RSS11R

SPECIFICATIONS

| | |
|-----------------------------------|---------|
| Working weight, stick mounted, kg | 1100 |
| Working weight, boom mounted, kg | 1200 |
| Operating pressure, bar | 250-300 |
| Oil flow range, l/min | 90-110 |
| Rotation working pressure, bar | 190-200 |
| Rotation oil flow, l/min | 10-15 |
| Carrier weight stick mounted, ton | 10-12 |
| Carrier weight boom mounted, ton | 7-10 |

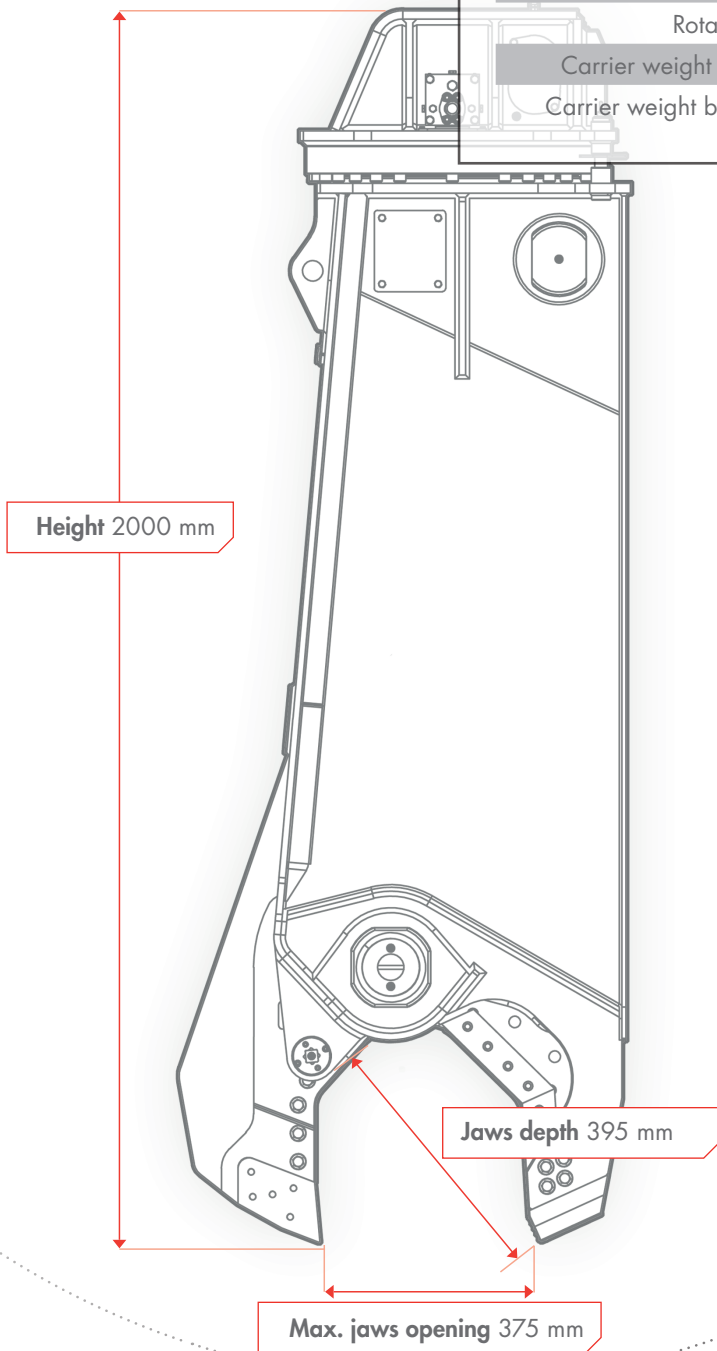

Sandvik Mining and Construction Oy
Taivalkatu 8, P.O.Box 165
FI-15101 Lahti, Finland
Phone Int. +358 205 44 151
www.rammer.com



Rammer[®]